



I N S T R U C T I O N M A N U A L

Mood Cluster

RGB LED wash effect with cluster & firework effects

9w RGB LED backwash effect with laser cluster and firework effects
Sound-to-Light, Auto, DMX and Master/Slave modes
8 channel DMX512 operation
XLR DMX in and out
Linkable Master/Slave in Sound-to-Light mode
40mW green laser / 100mW red laser
9w RGB LED wash effect
Numerous patterns available for selection
Fan cooled operation & tough metal chassis
Adjustable hanging bracket
Key operated power control

For the latest instruction manual updates and information on the entire Kam range visit:

www.kam.co.uk

Kam products are manufactured by: **Lamba plc**, Unit 1, Southfields Road, Dunstable, Bedfordshire, United Kingdom LU6 3EJ

Telephone: (+44) (0)1582 690600 • Fax: (+44) (0)1582 690400 • Email: mail@lambapl.com • Web: www.lambapl.com

If this product is ever no longer functional please take it to a recycling plant for environmentally friendly disposal.

Due to continuous product development, specifications and appearance are subject to change.

© COPYRIGHT LAMBA plc 2009. E&O E.

INTRODUCTION

Thank you for purchasing the KAM LED Mood Cluster.

To optimise the performance of this product, please read these operating instructions carefully to familiarize yourself with the basic operations of this unit. The KAM LED Mood Cluster has been designed to create amazing laser effects. Please keep these user instructions in a safe place for future reference. This unit has been tested at the factory before being shipped to you. There is no assembly required.

WARNING

To prevent or reduce the risk of electrical shock or fire, do not expose this unit to high temperature, rain or moisture.

Unintended reflections of the laser beam from reflective or metallic surfaces can be dangerous. Do not touch the laser aperture. When cleaning the laser Aperture, please use a soft cloth.

Laser Class 3B product. National regulations must be adhered to at all steps of installation. These can be downloaded from the website www.kam.co.uk (In Germany apply DIN 56912 and BGVR LASER note: additional regulations may apply).

Always replace the fuse with exact same type because anything other than the specified fuse can cause a fire, electric shock, damage your unit, and will void your manufactures warranty. This appliance must be earthed.

This appliance should be used by qualified personnel only.

UNPACKING YOUR NEW KAM PRODUCT

Carefully inspect your laser, as you unpack it. If any damage is evident, please notify the supplier you purchased the unit from immediately. For safety reasons do not use the unit if any damage has occurred during transportation.

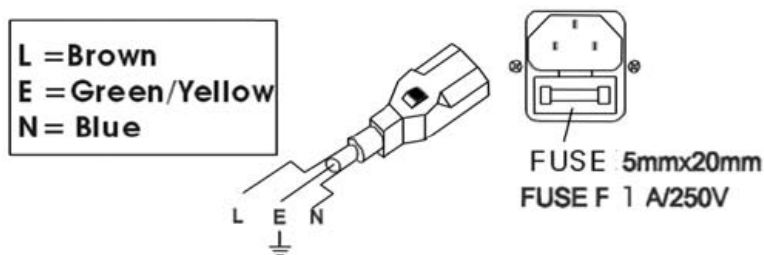

CONTENTS: Laser, mains lead, user manual and safety keys.

DMX-512 CONNECTION BETWEEN FIXTURES

The fixture is equipped with 3-pin XLR sockets for DMX input and output. The sockets are wired in parallel. Only use a shielded twisted-pair cable designed for 3-pin XLR-plugs and connectors in order to connect the controller with the fixture or one fixture with another.

OCCUPATION OF THE XLR-CONNECTION

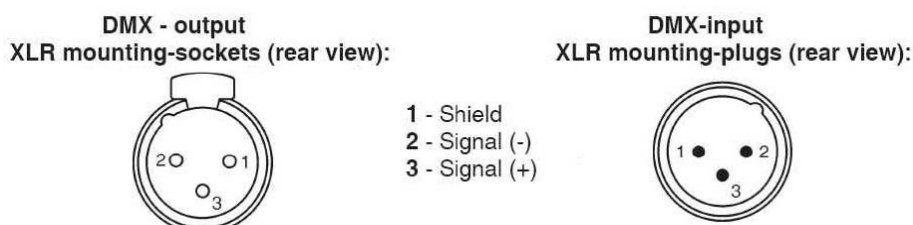

BUILDING A SERIAL DMX-CHAIN

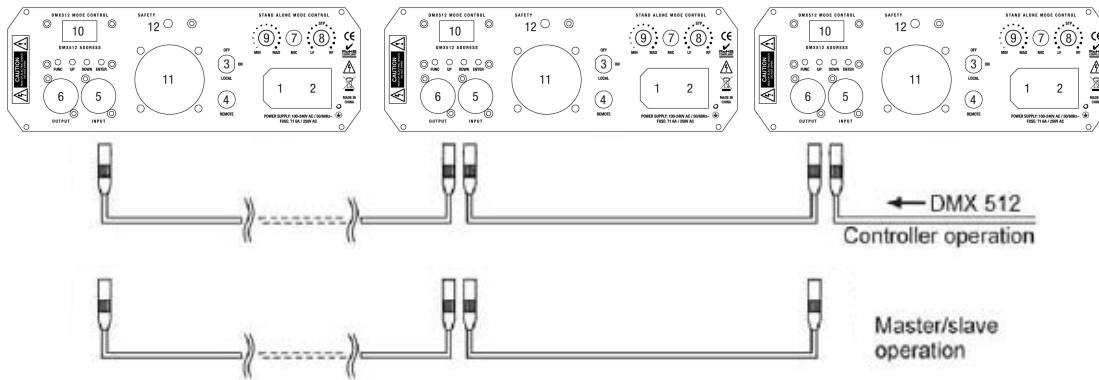

Master / slave no controller

Set the master unit to desired effect, use the menu button, followed by the up and down buttons to select desired master effect.

For example:

ASr	Auto mixed Slow laser effect with random order with manual control of led wash effect
-----	---

Then press the enter button to confirm selection

To set slave unit

Use the menu button and the up/down button to select "SLA"

Press the enter button to confirm selection.

Both units will now react the same (only one master unit should be set as master all other units to be set as slave)

Using DMX controller

Each fixture needs to have a DMX start address to receive the data from the controller. The DMX address number, which could be read from rear panel of each fixture and is between 000~511. Each unit uses 8 DMX channels.

If all units connected are to be controlled exactly the same, each unit must have the DMX start address set the same. For example, set all units to channel 001.

Use the menu button and then the up/down buttons to select the desired DMX start address, press enter to confirm your selection

Use a DMX cable to link the units together via the DMX in/out sockets on the rear panel. See above diagram.

Individual Control

To have DMX control over individual units each unit will need an individual start address. Each unit uses 8 DMX channels.

As before using the menu button then up/down set the desired DMX address. For example, unit 1 set to 001 unit 2 set to 009 etc. Adding 8 channels each time. Make sure no channels overlap.

Use a DMX cable to link the units together via the DMX in/out sockets on the rear panel. See above diagram

RIGGING THE FIXTURE

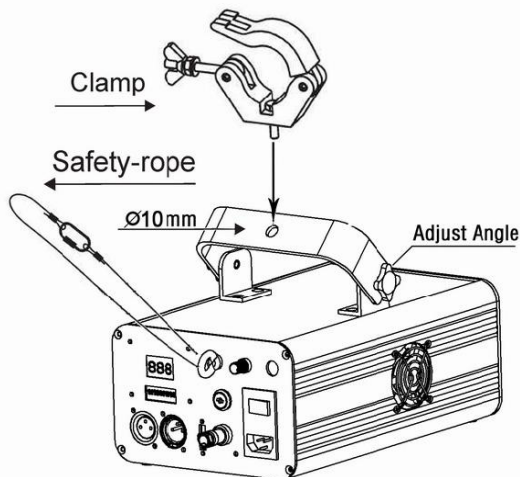

CAUTION: Please consider the respective national norms during the installation! The installation must only be carried out by an authorized employee or dealers! When installing the device, make sure there is no highly inflammable material (decoration articles, etc.) in between a distance of min 0.5m.

FRONT PANEL

NO.	NAME	DESCRIPTION
1	Laser Aperture	The laser effect output aperture. NEVER LOOK INSIDE THE FIXTURE THROUGH THIS APERTURE WHILE FIXTURE IS OPERATING.
2	LED Aperture	The LED effect output aperture.

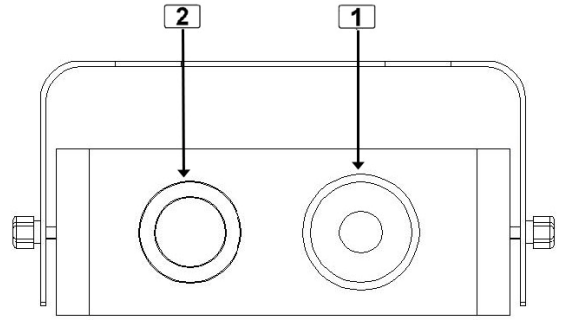

REAR PANEL

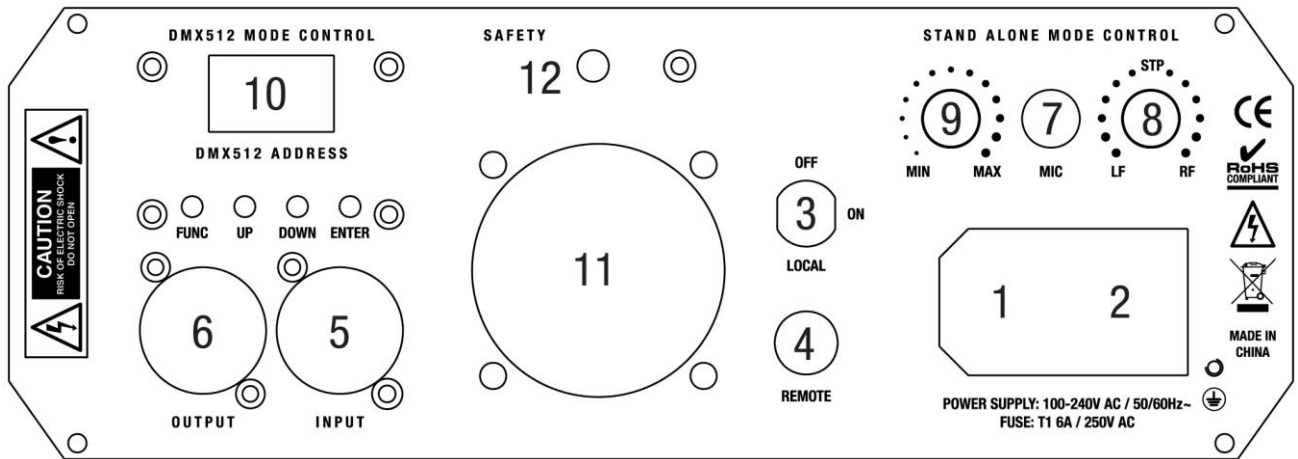

NO.	NAME	DESCRIPTION
1	Main Power Input	IEC socket and integrated fuse holder.
2	Power Switch	ON and OFF switch
3	Key Switch	Safety key switch unit will not operate with this turned off
4	Interlock	Used to connect an optional emergency stop button. When the contact is closed the laser will Black-out immediately. This must be wired by a qualified engineer
5	DMX input	3 pins male XLR connector
6	DMX output	3 pins female XLR connector
7	Microphone	To detect the music/sound signal
8	LED Speed	LED effect rotating speed
9	Mic Sensitivity Knob	Turning this knob clockwise increases the sound sensitivity
9	Mic Sensitivity Knob	Turn the knob (potentiometer) until the laser works in sync with the music.
10	Control Panel	To control the fixture with digital LED display, check more information on CONTROL & FUNCTION
11	Cooling	Forced air fan cooling
12	Safety eyelet	Attach safety chain or rope to this point

OPERATING MODE

When laser is powered on, LED monitor on rear panel shows the current operating standalone mode or DMX address of DMX mode. With help of LED control panel, it is very easy to set and change the operating mode of laser. After every resetting and saved, the new mode information will be shown on LED monitor at next power on.



Mode/Function Option, to choose the operating mode of laser.



Confirmation - to confirm all settings or change of LED control panel.



UP/DOWN, to change operating mode, parameter or DMX address.



Standalone pre-programmed laser show

Press FUNC to enter the mode option. Keep pressing until the LED panel shows one of the following: ArA, ASr, AFd, ASd, SrA, SSr, SFd, SSd.

Press UP or DOWN to select your favourite Standalone mode as above. Press ENTER to confirm the setting. The laser is working in stand alone. Each time when you turn on your laser, it will default to this setting.

In standalone mode, press the function button to choose a different program and the display will flash. Use the up and down buttons to select the desired mode then press enter to confirm.

DISPLAY	STAND ALONE MODE LASER EFFECT
ArA	Mixed laser effect show automatic mode with manual control of led wash effect
	Use led colour choice section to change led colour
ASr	Auto mixed S low laser effect with random order with manual control of led wash effect
	Use led colour choice section to change led colour
AFd	Auto F ast d ot laser effect with manual control of led wash effect
	Use led colour choice section to change led colour
ASd	Auto S low d ots laser effect with manual control of led wash effect
	Use led colour choice section to change led colour
SrA	Sound activated r Andom mixed laser effect with manual control of led wash effect
	Use led colour choice section to change led colour
SSr	Sound activated S low random mixed laser effect with manual control of led wash effect
	Use led colour choice section to change led colour
SFd	Sound activated F ast moving d ots laser effect with manual control of led wash effect
	Use led colour choice section to change led colour
SSd	Sound active S low moving d ots laser effect with manual control of led wash effect
	Use led colour choice section to change led colour

LED colour choice

Press FUNC to enter mode option.

Keep pressing until the LED panel shows either one of LEd, Loo, rAn, -r-, -Y-, -G-, -C-, -b-, -P- & -W-. colours explained in grid below.

Press UP or DOWN to select your favourite LED colour as above. Press ENTER to confirm the setting. The LED will be in the colour which you selected. Each time you turn on your laser, it will default to this colour option.

In the COLOUR CHOICE setting, the LED COLOUR that you are going to choose will flash. Press UP or DOWN to change the LED colour, you will have 10 different LED colour modes. Their display and effects are listed below:

DISPLAY	LED COLOUR	DISPLAY	LED COLOUR
LEd	LED Colour	-G-	Green
Loo	Colour Looping	-C-	Cyan
rAn	Colour Random	-b-	Blue
-r-	Red	-P-	Purple
-Y-	Yellow	☐	White

Master/slave mode

Press FUNC to enter mode option. Keep pressing until the LED panel shows SLA. Press ENTER to confirm the setting.

The laser is working in slave mode. Connect master laser and slave lasers with DMX cable, the SLAVE lasers will do exactly what the master laser does.

DMX mode

Press FUNC to enter MODE OPTION

Until the LED panel shows 001.

Press ENTER to confirm the setting.

The laser is working in "DMX MODE". With help of UP/DOWN button, change the number to the desired DMX start address.

DMX protocol

CHANNEL	DMX VALUE	DESCRIPTION
1 - MODE	000-025	Laser Black Out
	026-050	Mixed laser effect Auto show with rAndom led
	051-075	Auto mixed Slow laser effect with random led
	076-100	Auto Fast dots laser effect
	101-125	Auto Slow dots laser effect
	126-150	Sound activated rAndom mixed laser effect
	151-175	Sound activated Slow random laser effect
	176-200	Sound activated Fast moving dots laser effect
	201-225	Sound active Slow moving dots laser effect
	225-255	DMX MODE
2 – ROTATION SPEED AND DIRECTION	000-128	Anti-clockwise Rotation
	129-138	Stop
	139-255	Clockwise Rotation
3 - VIBRATE	000-255	vibrating Range
4 - FLASH	000-005	Stop
	006-255	Flash
5 – COLOUR MODE	000-036	Black Out
	037-072	Red
	073-108	Green
	109-144	Red & Green (To alternate colour use ch6)
	145-180	Red and green, to strobe Green use ch6 also
	181-216	Green and red to strobe red use ch6
	217-255	Both Red and Green to strobe use ch6
6 - STROBE	000-127	NO Strobe
	128-255	Speed of strobe
7 - LED COLOUR MODE To activate CH 7 – CH8 value must be set to 4	000-025	No Strobe
	026-050	White
	051-075	Purple
	076-100	Blue
	101-125	Cyan
	126-150	Green
	151-175	Yellow
	176-200	Red
To adjust speed use CH8	201-225	Looping Colour Strobing
	226-255	Random Colour Strobing
8 - LED STROBE	000-003	NO Strobe
	000-255	Fast to Slow

LASER EMISSION DATA

Laser Classification	Class 3B
Green Laser medium	DPSS Nd:YVO4, 532nm
Red laser medium	LD GaAlAs 650nm, typical
Beam diameter	<5mm at aperture
Pulse data	All pulses < 4Hz (>0.25sec)
Divergence (each beam)	<2 mrad
Divergence (total light)	<160 degrees
Laser Power	Red>100mW, Green>40mW

* As measured under IEC measurement conditions for classification.

LASER COMPLIANCE STATEMENT

This laser product complies with EN/IEC 60825-1 Ed 2, 2007-03, and US FDA/CDRH FLPPS via the terms of Laser Notice No. 50 dated June 24, 2007.

SPECIFICATIONS

Mains Input: AC100-240V, 50/60Hz

Fuse: 250V 1.6A Slow Blow (20mm Glass)

Total Power: 25W

Music Control: Internal microphone

Laser Power: 40mW 532nm Green CW

100mW 650nm Red CW

Laser Classification: Class 3B

Laser Safety Standard: EN60825-1 2007

Condition Temperature: 10~40°C

DMX Connections: 3 pins XLR Male/Female

DMX Channels: 8 channels

Measurement: See diagram below

N Weight: 2.8 Kg